

PORT #	PORT SIZE
2	1/8"
3	1/4"
4	3/8"
	1/2"
	3/4"



1

1. First hold the housing of the joint with a bench vise. Do not clamp too tightly, it will damage housing or bearings.

2. Apply sealant/adhesive or teflon tape to the threads of the hoses and assemble them to the housing.

3. If housing connections are SAE Flange, place o-rings into the grooves and fix flanges of the hoses with appropriate bolts.

4. If shaft outlets are threaded, apply sealant/adhesive or teflon tape to the threads of the outlet houses and assemble to the shaft.

5. Clean rotating joint flange face and machine bore surface before assembling.

6. If shaft outlets are with o-rings&grooves; place o-rings into the grooves of the shaft flange. Apply grease slightly to fix the o-rings inside the grooves.

7. Align rotating joint flange and machine bore flange.

8. If shaft outlets are with o-rings&grooves; align flange plot bore and flow channels to the machine bore and flow channels; fix the shaft to the machine with appropriate bolts.

9. If shaft outlets are threaded, align shaft outlets with machine connections and fix the shaft to the machine with appropriate bolts.

10. Do not pipe directly. It may create excessive side loads and damage the joint.

11. Attach an anti rotation rod to anti rotation connection of the housing. Be sure that one end of the rod is fixed to the housing and the other end floats freely.

12. Rigid connection of the anti rotation rod will damage the joint.

13. If shaft flange connections are threaded; connect hoses on the shaft to the machine connections.

14. Connect hoses on the housing to the supply lines.

15. After assembly, check rotating joint for leakage. A small amount of leakage may be seen in the starting period. Never use leaking joint.

16 After assembly; control rotation of joint. If any wobble, vibration, knocking or noise show up or if any eccentricity seems; disassemble the joint from the machine and assemble it again.

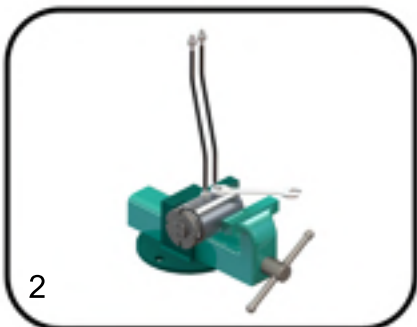

2

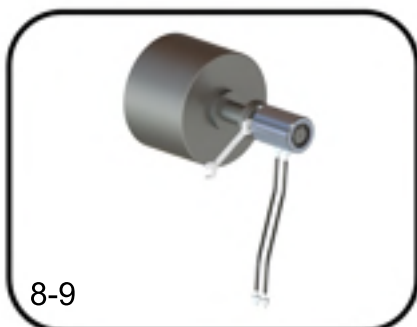

8-9

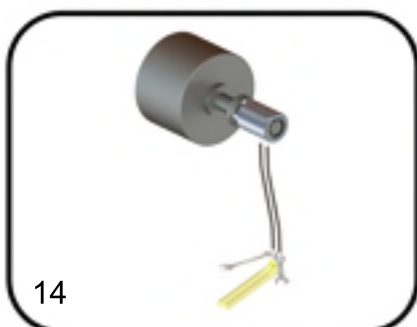

14