

SIZE	SINGLE FLOW MODEL	DUAL FLOW MODEL
1/2"	Q15-1/2"	Q20-1/2"
3/4"	Q20-3/4"	Q25-3/4"
1"	Q25-1"	Q40-1"
1 1/2"	Q40-1 1/2"	-----

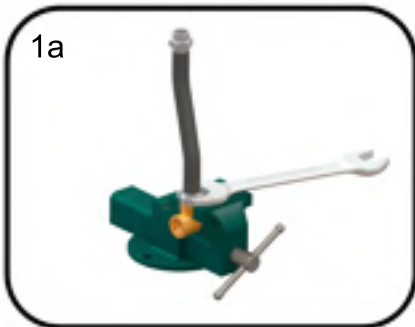

1a

1. First hold the elbow with a bench wise;
 - 1.a) If single flow;
 - Assemble the inlet hose
 - 1.b) If dual flow;
 - Assemble the inlet and outlet hoses
 - Place pim on the hole of the internal pipe
 - Assemble the internal pipe to the elbow, be sure that the internal pipe is fixed to the dual flow elbow

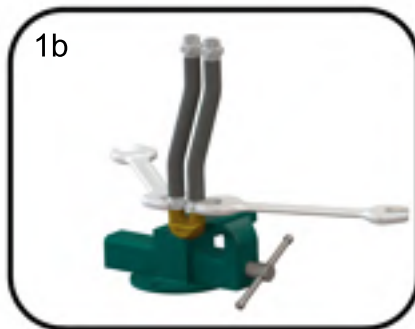

1b

2. Clean machine bore surface before assembling.

3. Apply grease slightly inside the machine bore.

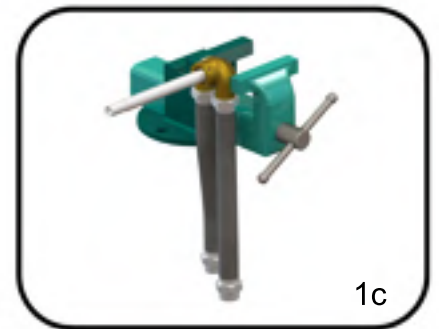

1c



4

4. Be careful not to damage the o-rings on the housing when assembling the housing to the machine.

5. Align bolt holes of the machine with bolt holes of the flange of the housing and fix the flange with appropriate bolts to the machine in a star shape.

6. Apply grease inside the surfaces of the elbow.

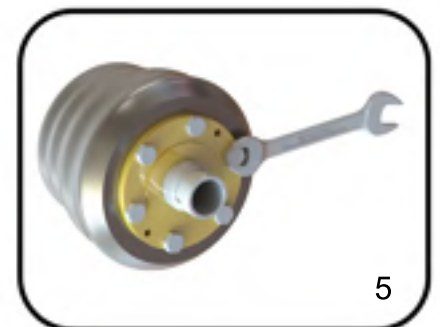

5



7. Assemble the elbow onto the shaft until bolts and bolt channel on the shaft are aligned.



8. Fix the elbow to the shaft by tightening two bolts on the elbow. Fix the nut on the bolts so that bolts won't loosen.

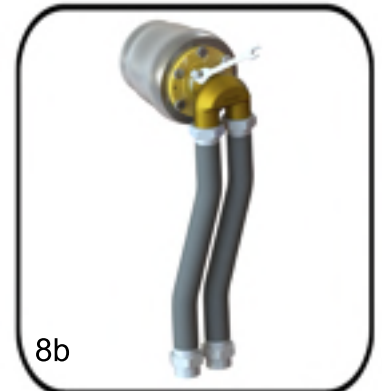

9. Connect hoses to the supply and return lines. Use flexible hoses and never install joint directly to the pipes.

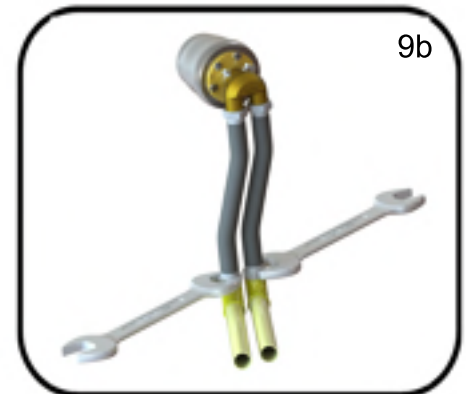

10. Assemble hoses without sharp bends or without stress. Rotary joints are designed to float with the hoses.

11. Install hoses with curves in direction of rotation.

12. Flexible hoses must not be twisted during operation. Twisted hoses lose flexibility. Use pipe fittings for proper installation.

13. If rotating joint and pipe axis are not on the same axis, hose must be installed with a smooth curve.

14. Flexible hoses must not be twisted during operation. Use proper pipe fittings.

15. After assembly; control rotation of joint. If any noise, wobble, vibration, knocking or noise show up or if any eccentricity seems; disassemble the joint from the machine and assemble it again.